



## Sheath Fault Locator



### SERVICE CENTER, SALES AND TECHNICAL SUPPORT INFORMATION

Corporate Headquarters  
3251 Olcott Street  
Santa Clara, CA 95054  
800-446-3392  
408-734-1400 Direct  
408-734-1415 Fax  
[www.metrotech.com](http://www.metrotech.com)  
[sales@metrotech.com](mailto:sales@metrotech.com)

Metrotech Eastern U.S. Service Center  
1824 Murfreesboro Road, Ste. 104  
Nashville, TN 37217  
800-624-6210  
615-366-7323 Direct  
615-360-9855 Fax  
[nashville@metrotech.com](mailto:nashville@metrotech.com)

Metrotech European Service Center  
Seba KMT  
Dr. Herbert Iann St. 6  
96148 Baunach, Germany  
+49 9544 680  
+49 9544 2273 Fax  
[service@sebakmt.com](mailto:service@sebakmt.com)



**ISO 9001 CERTIFIED**

Metrotech has received ISO 9001 Quality Management System Certification.

Metrotech adheres to the quality standard guidelines of ISO 9001 and ensures quality in its design/development, production, installation, and servicing disciplines.

**© Metrotech Corporation 2005-2008**

**Metrotech Corporation  
3251 Olcott Street  
Santa Clara, CA 95054  
USA**

**Tel: 1.800.446.3392; 1.408.734.1400  
Fax: 1.408.734.1415  
E-mail: [sales@metrotech.com](mailto:sales@metrotech.com)  
Internet: [www.metrotech.com](http://www.metrotech.com)**

Revision C: 12/1/07

# TABLE OF CONTENTS

|   |           |
|---|-----------|
| <b>List of Illustrations .....</b>                                    | <b>1</b>  |
| <b>1 Introduction.....</b>  | <b>2</b>  |
| <b>2 Safety Precautions.....</b>                                      | <b>3</b>  |
| <b>3 9800XT SFL-2 Quick Start Guide for the Experienced User.....</b> | <b>4</b>  |
| <b>4 9800XT SFL-2 Equipment.....</b>                                  | <b>10</b> |
| 4.1 Standard Equipment.....   | 10        |
| 4.2 Optional Accessories.....   | 12        |
| 4.3 Technical Specifications.....                                     | 13        |
| 4.4 Transmitter Controls and Indicators.....                          | 16        |
| 4.5 Transmitter Features.....   | 18        |
| 4.6 A-Frame Receiver Controls and Indicators.....                     | 20        |
| 4.7 Additional A-Frame Receiver Features.....                         | 21        |
| <b>5 Principles of Operation.....</b>                                 | <b>22</b> |
| 5.1 Functional Theory.....  | 22        |
| 5.1.1 Earth Voltage Gradient.....                                     | 24        |
| 5.1.2 Equipotentials.....   | 24        |
| 5.1.3 Multiple Fault Patterns.....                                    | 26        |
| 5.1.4 Distortion Due to Adjacent Conductors.....                      | 26        |
| <b>6 Checkout Procedure.....</b>                                      | <b>27</b> |
| <b>7 Operation.....</b>   | <b>29</b> |
| 7.1 Check the Batteries Prior to Going into the Field.....            | 29        |
| 7.2 Ensure all conductors are de-energized.....                       | 29        |
| 7.3 Lift the Grounds.....   | 29        |
| 7.4 Attach the Transmitter to the Conductor-Check Fault Resistance .. | 29        |
| 7.5 Synchronize the A-Frame Receiver.....                             | 30        |
| 7.6 Confirm that a Fault Exists.....                                  | 32        |
| 7.7 Trace the Cable with the 9800 Receiver.....                       | 32        |
| 7.8 Pinpoint the Fault.....   | 32        |
| 7.9 Verify the Fault.....   | 32        |

|          |   |           |
|----------|---|-----------|
| <b>8</b> | <b>Advanced Techniques.....</b>         | <b>33</b> |
| 8.1      | Faults Under Inaccessible Surfaces..... | 33        |
| 8.1.1    | Perpendicular Method.....               | 33        |
| 8.1.2    | Triangulation Method.....               | 34        |
| 8.2      | Faults Under Pavement.....              | 35        |
| 8.3      | Long Distance Tracing.....              | 35        |
| 8.4      | High and Low Impedance Faults.....      | 36        |
| 8.5      | Multiple Faults.....                    | 36        |
| <b>9</b> | <b>Maintenance.....</b>                 | <b>37</b> |
| 9.1      | Receiver Battery Replacement.....       | 37        |
| 9.2      | Service Center.....                     | 38        |
|          | <b>Appendix .....</b>                   | <b>39</b> |
|          | <b>Copyright.....</b>                   | <b>40</b> |
|          | <b>Warranty.....</b>                    | <b>41</b> |

## LIST OF ILLUSTRATIONS

|  |           |
|--|-----------|
| <b>Figure 3-1: Fault Resistance Scale.. . . . .</b>  | <b>4</b>  |
| <b>Figure 3-2: Clamping Black Lead to Ground Rod.....</b>                                  | <b>5</b>  |
| <b>Figure 3-3: Clamping Red Lead to Targeted Cable.....</b>                                | <b>5</b>  |
| <b>Figure 3-4: Locating the Targeted Cable.....</b>  | <b>5</b>  |
| <b>Figure 3-5: Positioning of A-Frame Receiver for Synchronization.....</b>                | <b>6</b>  |
| <b>Figure 3-6: Locating the Cable Fault with A-Frame Receiver.....</b>                     | <b>7</b>  |
| <b>Figure 4-1: Standard Equipment and Accessories. . . . .</b>                             | <b>11</b> |
| <b>Figure 4-2: Transmitter Controls Panel.....</b>   | <b>16</b> |
| <b>Figure 4-3: A-Frame Controls and Indicators. . . . .</b>                                | <b>20</b> |
| <b>Figure 5-1: Typical SFL-2 Transmitter Connection.....</b>                               | <b>23</b> |
| <b>Figure 5-2: Signal Pattern Around Fault and Ground Point.....</b>                       | <b>24</b> |
| <b>Figure 5-3: Multiple Fault Signal Patterns.....</b>                                     | <b>26</b> |
| <b>Figure 6-1: Checkout Test Set-Up.....</b>   | <b>27</b> |
| <b>Figure 7-1: Synchronizing the A-frame.....</b>  | <b>30</b> |
| <b>Figure 7-2: Fault Confirmation.....</b>   | <b>31</b> |
| <b>Figure 8-1: Perpendicular Method.....</b>   | <b>33</b> |
| <b>Figure 8-2: Triangulation Method.....</b>   | <b>34</b> |
| <b>Figure 8-3: Locating an Equipotential Circle.....</b>                                   | <b>34</b> |
| <b>Figure 8-4: Fault Location Using Extension Cable for<br/>Increased Sensitivity.....</b> | <b>35</b> |
| <b>Figure 9-1: Receiver Battery Replacement.....</b>                                       | <b>37</b> |

# 1 INTRODUCTION

The Metrotech 9800SFL Sheath Fault Locator system is designed to detect and pinpoint sheath and other conductor faults that are in direct contact with the earth.

The 9800SFL offers these unique features:

- ◆ **Fault level measurement at the Transmitter**
- ◆ **Simultaneous fault finding and line tracing.**
- ◆ **Signal strength LCD on the A-Frame for judging proximity to faults, comparing multiple faults, and detecting pinholes and “trees” in power cable.**
- ◆ **Detection of low and high resistance faults.**
- ◆ **Automatic battery checking and low battery warning**
- ◆ **Non-polarized A-Frame.**
- ◆ **Single-handed operation. No need to carry locator receiver as well as A-frame.**

Operation of the unit is completely automatic; there are no operator adjustments required. Both the Transmitter and Receiver are water resistant and built to withstand the rigors of field use.

## 2 SAFETY PRECAUTIONS

- 1 Metrotech Utility Line and Sheath Fault Locators are intended for use by utility and contractor professionals. Safety hazards for underground utility access areas include electrical shock, explosive gases, and toxic fumes as well as potential influence on communications and control systems such as traffic control and railroad crossings.
- 2 Familiarize yourself with all required safety practices of the local utility company, or other owner of the plant before entering an access area or connecting a Metrotech transmitter.
- 3 **Before connecting transmitter directly to any conductor, make sure that the line is de-energized and out of service. Never make a direct connection to a live power cable.**
- 4 If you use the Metroclamp on energized electrical or control lines follow appropriate safety procedures to avoid the risk of injury.
- 5 Pay special attention when using a locator in high traffic areas.

### 3 9800XT SFL-2 SHEATH FAULT LOCATOR QUICK START FOR THE EXPERIENCED USER

#### 1 Check Batteries Prior to Departing for the Field

Check the batteries in the Transmitter, Receiver, and A-Frame. Replace/recharge if necessary. Turn the instruments off.

#### 2 Ensure all conductors are de-energized

#### 3 Lift Grounds

Lift Grounds (of all conductors in the circuit) at both ends of the faulted cable section.

#### WARNING

When the Transmitter is set to “SFL”, the external OUTPUT JACKS produce High Voltage. **Do not touch these jacks, electrical shock will result!**

#### 4 Attach Transmitter to Conductor – Check Fault Resistance

- 1 Turn Transmitter “OFF.”
- 2 Plug Black and Red leads into the Transmitter.
- 3 Stretch Black-lead 180 degrees away from conductor.
- 4 Push grounding rod into earth and clamp black lead to grounding rod. Establish the best ground possible. **See figure 3-2**
- 5 Clamp Red lead to target conductor sheath. **See Figure 3-3**
- 6 Turn Transmitter power knob to “SFL” position.

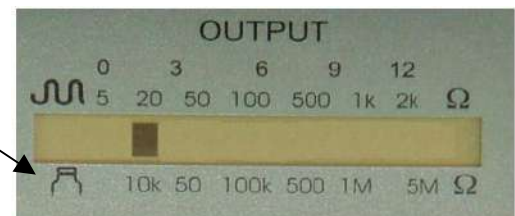
Check fault resistance scale: **See Figure 3-1**

0-100k ohms – Severe Fault

100k – 500k ohms – Medium Fault

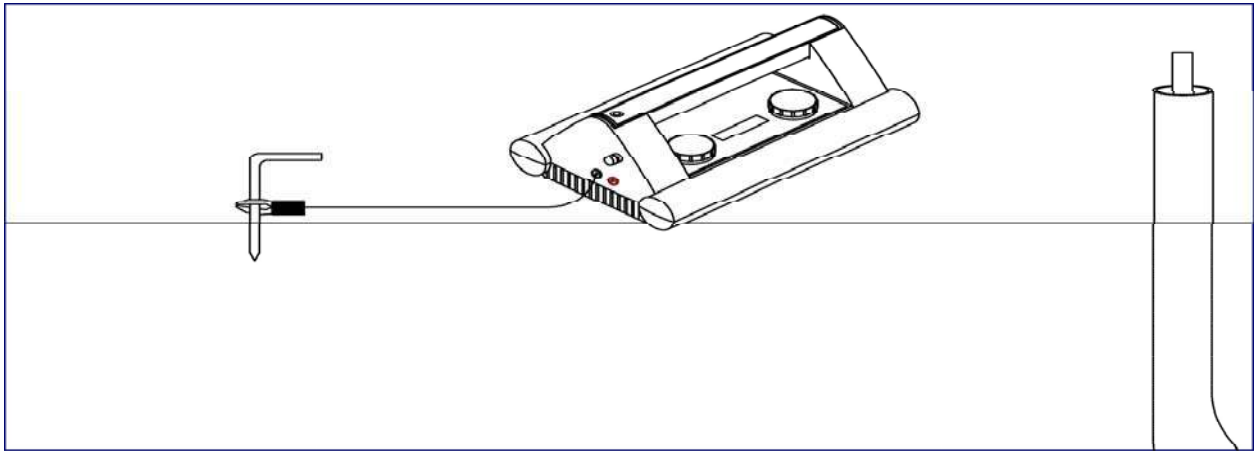
1 Megohm and above – Light Faults

**Note:** Read the number below the oscillating bar to check the quality of the targeted cable. The fault resistance on **Figure 3-1** is 10K ohms (Severe Fault).

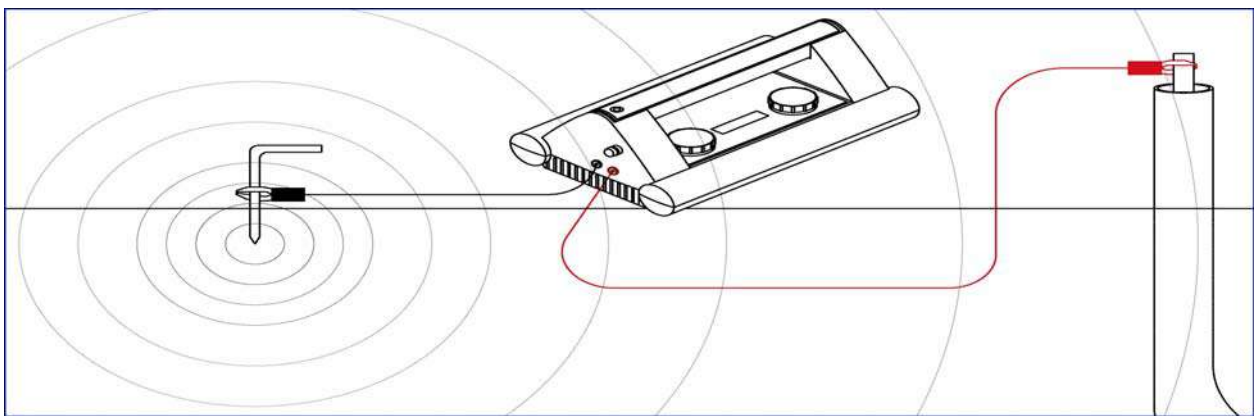


**Figure 3-1: Fault Resistance Scale**





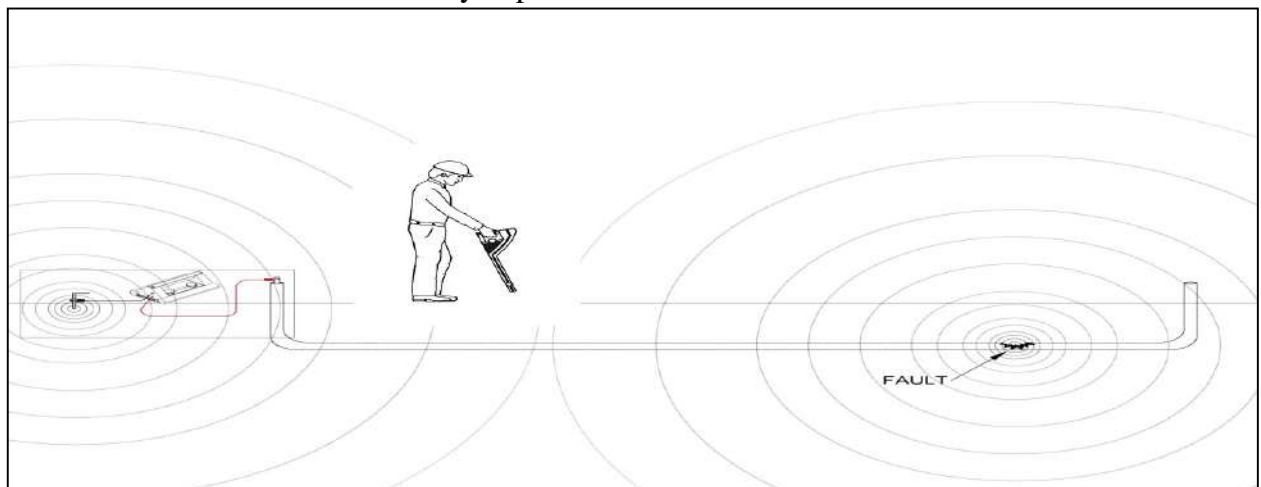
**Figure 3-2: Clamping Black Lead to Ground Rod**



**Figure 3-3: Clamping Red Lead to Conductor**

**5 Use the 9800XT Line Locator Receiver to Trace the Cable**

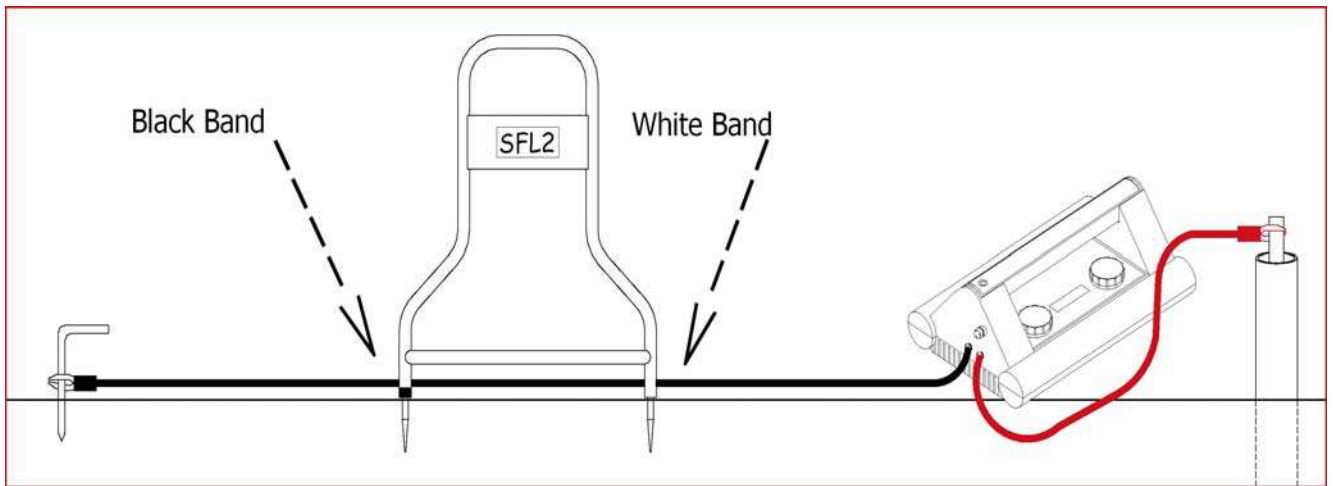
Trace and mark the cable as you proceed towards the fault.



**Figure 3-4: Locating the Targeted Cable**

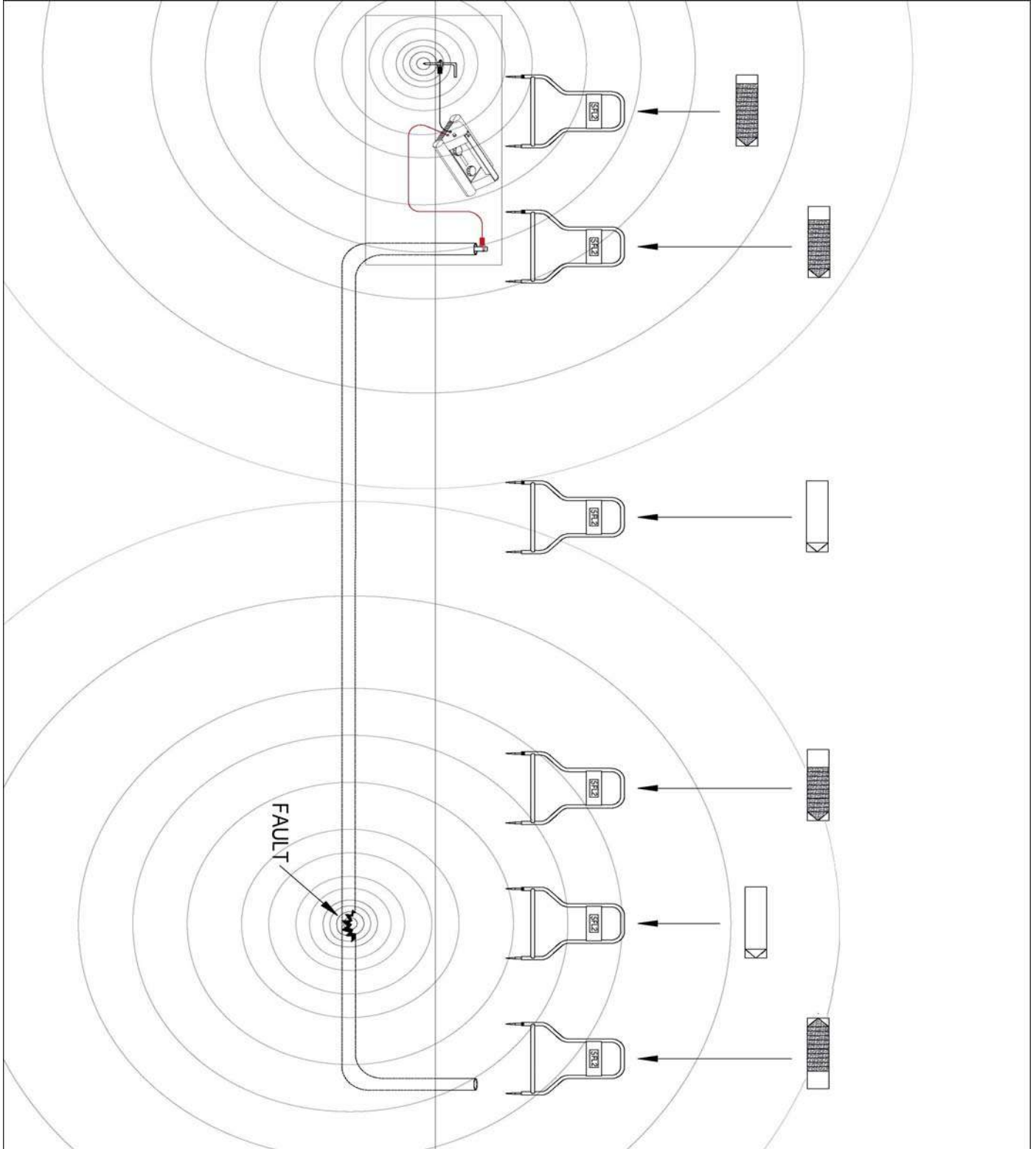
**5 Synchronize the A-Frame Receiver and establish reference value of fault  
(A-Frame receiver has a one-color band above each spike (Black or White))**

- 1 Hold the A-Frame Receiver so the spike with the black band is about 2 steps away from the ground rod and the spike with the white band is in-line with the targeted cable. The A-frame receiver **must be placed** as shown in **figure 3-5** for synchronization and for unit to operate correctly. Push the A-Frame spikes into the ground. Switch the Receiver “ON” wait until arrow flashes.



**Figure 3-5: Positioning of A-Frame Receiver for Synchronization**

- 2 Monitor bar-graph LCD display for arrow direction. If the arrow points away from the ground rod, there is a fault.
- 3 If the arrow points towards the ground rod, there is no fault, and grounds and connections need to be rechecked
- 4 The number of bars on the LCD indicates the potential gradient associated with the fault at the synchronization location.
- 5 The number of bars will decrease when you move away from the synchronization location and will increase when you get closer to the targeted fault. **See Figure 3-6.**



**Figure 3-6 : Locating the Cable Fault with A-Frame Receiver**

## **6 Pinpoint the Fault**

- 1 Keep the A-Frame parallel to the target cable.
- 2 Insert the A-Frame every 10-20 ft. Follow the arrow.
- 3 When the arrow changes direction, backtrack. Look at the number of bars activated and compare them to number of bars you read at synchronization point. If the number of bars is similar to the number of bars at synchronization point, you have located the main fault.
- 4 Insert the A-Frame every two feet until the arrow changes direction again.
- 5 Move the A-Frame across the cable until a slight movement causes the arrow to change direction. The fault is located at the center of the A-Frame.
- 6 Check entire cable for multiple faults. If more faults are present, check the active number at each fault site and compare it to the reference number. The higher the active number the larger the fault.

If you have difficulty with your Metrotech SFL-2 Sheath Fault Locator, check the manual for additional tips. For Assistance, call us at 1-800-446-3392.

**NOTE:** This equipment has been tested and found to comply within limits for a Class B digital device, pursuant to Part 15 of the FCC Rules. These limits are designed to provide reasonable protection against harmful interference in residential installations. This equipment generates, uses, and can radiate radio frequency energy. If not installed and used in accordance with the instructions, it may cause harmful interference to radio communications. However, there is no guarantee that interference will not occur in a particular installation. If this equipment does cause interference to radio or television reception (Which can be determined by turning to the locating equipment off and on). We suggest the user try to eliminate the interference by one or more of the following measures:

- ◆ Reorient or relocate the receiving antenna.
- ◆ Move the equipment away from the Receiver.
- ◆ Plug the equipment into an outlet on a circuit different from that to which the Receiver powered. If necessary, the user should consult the dealer or an experienced radio/television technician for additional suggestions.

**CAUTION:** Only equipment certified to comply with Class B (computer input/output devices, terminals, printers, etc.) should be attached to this equipment. Finally, any changes or modifications to the equipment by the user not expressly approved by the guarantor or manufacturer could void the users authority to operate such equipment.

## 4 MODEL 9800XT SFL EQUIPMENT

### 4.1 Standard Equipment

The SFL transmitter is an option to the 9860XT and 9890XT Locator System and is designated by the 'F' in the Part Number. When the SFL option is selected, the standard equipment may include:

| <b>Part Model #</b> | <b>Description</b>                             | <b>Remarks</b>   |
|---------------------|--|------------------|
| 9860XT_FXT          | 4.8 Hz, 9.82kHz, 82 kHz                        | Transmitter      |
| 9890XT_FXT          | 4.8Hz, 982 Hz, 9.8 kHz, 82 kHz                 | Transmitter      |
| 9860XT_FXT          | 9.82kHz, 82 kHz, 50/60 Hz,<br>14-22 kHz        | Receiver         |
| 9890XT_FXT          | 982 Hz, 9.8 kHz, 82 kHz<br>50/60 Hz, 14-22 kHz | Receiver         |
| 10498               | 4.8Hz  | A-Frame Receiver |
| 400B196-1           | Red Test Cable                                 |                  |
| 400B196-2           | Black Test Cable                               |                  |
| 600A113             | Operating Manual                               |                  |
| 500B353             | Foam pads                                      |                  |



**Figure 4-1: Standard Equipment and Accessories**

**Standard:**

1. 9800XT Receiver
2. 9800XT Transmitter
3. Conductive Attachments
4. Ground Rod
5. Carrying Case
6. SFL – 2 Receiver
7. Operation Manual

**Accessories:**

8. MetroClamp
9. Flex-Sonde
10. High Power Sonde
11. Standard Power Sonde

## 4.2 Optional Accessories

Optional accessories available for the 9800XT Sheath Fault Locator are listed below:

| <b><u>Part/Model #</u></b> | <b><u>Description</u></b>      | <b><u>Remarks</u></b>                           |
|----------------------------|--------------------------------|---|
| 4290                       | 2" Metroclamp and jumper cable | For Inductive Coupling or Cable ID              |
| 4490                       | 4" Metroclamp and jumper cable | For Inductive Coupling or Cable ID              |
| 4890                       | 8" Metroclamp and jumper cable | For Inductive Coupling or Cable ID              |
| 400B246                    | Conductive Attachment          | Telephone style Clips                           |
| 400A132                    | 100' Ground Lead Extension     |   |
| 400B252                    | Vehicle Mount Charger          | For use with rechargeable transmitter batteries |
| 500D082                    | A-Frame Carrying Case          |   |
| 183048                     | Head Phones                    | For use in high noise level areas               |
| 10126                      | Live Power Connector           | Use at 9.8kHz                                   |
| 158084                     | Search Coil                    | For Cable and pair ID                           |



### 4.3 Technical Specifications

#### TRANSMITTER

|                            |              |                              |
|----------------------------|--------------|------------------------------|
| <b>Output Frequencies:</b> | <b>Model</b> | <b>Frequencies</b>           |
|                            | 9860XT*      | 4.8Hz, 9.82kHz, 82kHz        |
|                            | 9890XT*      | 4.8Hz, 982Hz, 9.82kHz, 82kHz |

**Audio Output:** Pulsing tone to indicate Transmitter output is active.

**Line Tracing Ohmmeter:** 0-2 kOhm

**Fault Metering:** Continuous fault resistance monitoring 0 to 10M Ohm.

#### Automatic "Best" Frequency Selection

#### Nominal Output Power

|                         |  |              |
|-------------------------|--|--------------|
| <b>Conductive Mode:</b> | <b>Model</b>                           | <b>Watts</b> |
|                         | 9860XT                                 | 3*           |
|                         | 9890XT                                 | 3*           |
|                         | * Output power limited to .7W at 82kHz |              |

**Power Settings:** Low and High (all models)

**Battery Type:** Ten D Cells  
Optional Rechargeable NiCd

**Battery Life:** Alkaline 28-70 hours  
NiCd 9-22 hours Continuous use,  
depending on power and Frequency selection.

**Battery Check:** Automatic at start up

#### Operation

**Temperature:** -4° to +122° F (-20° to +50° C)

**Dimensions:** 14.25"L x 9.25"W x 5.25"H  
(36.2 cm x 23.5 cm x 13.3 cm)

**Weight:** 8.9 lbs. (4 kg)

**Technical Specifications (4.3 cont'd)****A-FRAME RECEIVER**

|                             |   |
|-----------------------------|---|
| <b>Frequency:</b>           | 4.8 Hz Crystal Controlled   |
| <b>Input Sensitivity:</b>   | 5 MV  |
| <b>Sensitivity Control:</b> | Automatic   |
| <b>Dynamic Range:</b>       |   |
| Bargraph                    | 72 dB   |
| <b>Output Indication:</b>   |   |
| Bargraph LCD                | Flashing LCD arrows point to fault 12 segment LCD bar graph indicates signal level, each bar = 6dB. |
| <b>Battery:</b>             | 9 V NEDA 1604 or equivalent.  |
| <b>Battery Life:</b>        | 100 hours continuous use.   |
| <b>Battery Test.</b>        | Automatic at power on   |
| <b>Weight:</b>              | 4.4 lb (2.0 kg)   |
| <b>Dimensions:</b>          | 32 in. H x 22 in. W x 1 in.<br>(81 cm x 56 cm x 2.5 cm)   |
| <b>Operational Temp:</b>    | -4 to + 120 degrees F   |

**Technical Specifications (4.3 cont'd)****9800XT Receiver**

| <b>Frequencies:</b> | <b>Model</b> | <b>Frequencies</b>  |
|---------------------|--------------|---|
|                     | 9860XT       | Active - 9.82kHz, 82kHz<br>Passive - 50/60Hz, 14-22kHz        |
|                     | 9890XT       | Active - 982Hz, 9.82kHz, 82kHz<br>Passive - 50/60Hz, 14-22kHz |

**Depth****Readout**

**Accuracy:** Passive- $\pm(5\% + 2'')$  under normal conditions  
Active-  $\pm(5\% + 2'')$  under normal conditions

**Distance Sensitive Left/Right Guidance™****Real-Time Continuous Gain Adjustment™ and Manual Gain Control****Simultaneous Peak and Null Display™****Current Measurement**

**Backlighting:** Standard on all 9800XT receivers

**Serial link:** RS232

**Battery Type:** Six AA Cells

**Battery Life:** 30 hours continuous use  
24 hours continuous backlit use

**Battery Check:** Continuous Automatic Operation  
**Temperature:** -4° to +122° F (-20° to +50° C)

**Dimensions:** 27"L x 7"W x 9"H  
(68.6 cm x 17.8 cm x 22.9 cm)

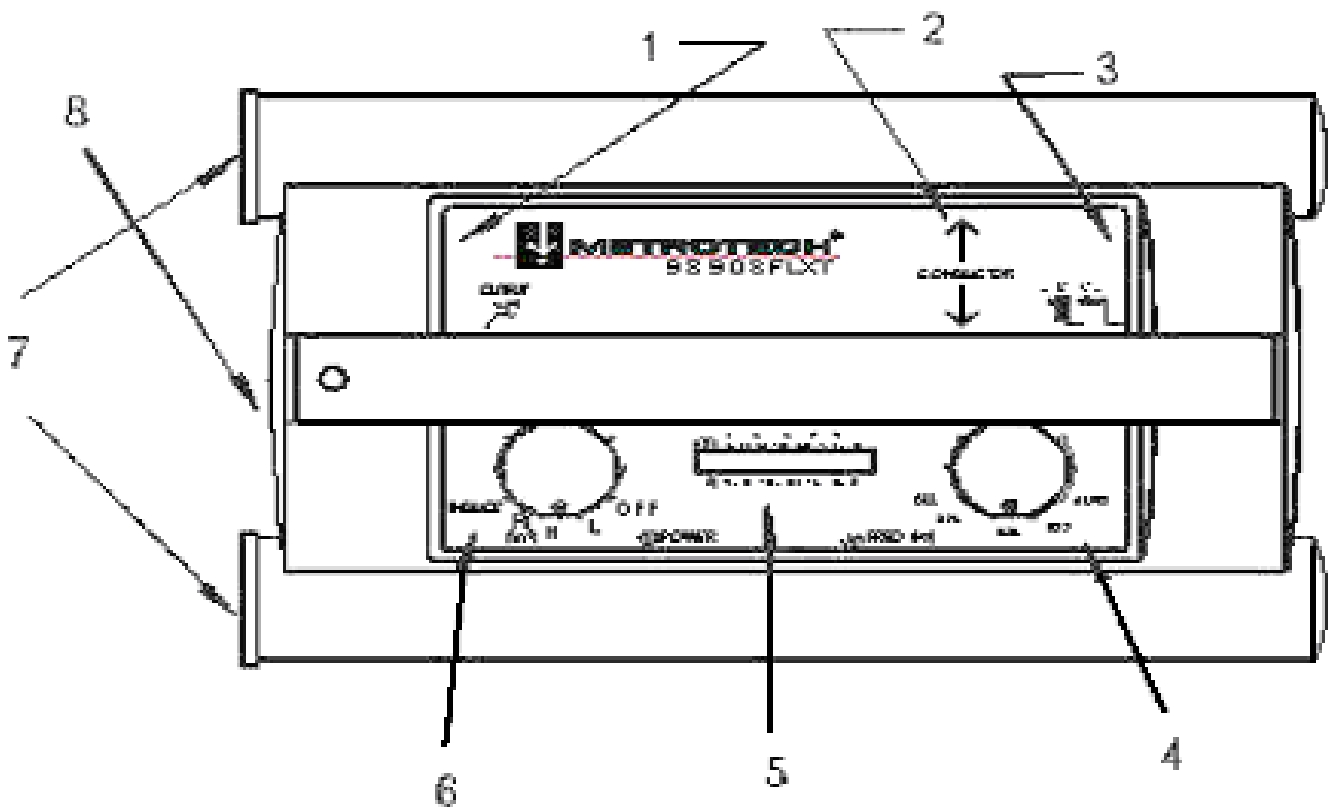
**Weight:** 5.4 lbs. (2.35 kg)

#### 4.4 Transmitter: Controls and Indicators

##### WARNING

When the Transmitter is set to “SFL”, the external OUTPUT JACKS produce high voltage. **Do not touch these jacks, electrical shock will result!**

See **Figure 4-2** for location of Transmitter controls and indicators described below:



**Figure 4-2: Transmitter Control Panel**

- |   |                                       |
|---|---------------------------------------|
| 1 | Output Clamp Jack                     |
| 2 | Conductor Arrow                       |
| 3 | Charge Jack                           |
| 4 | Frequency Knob                        |
| 5 | LCD Display                           |
| 6 | Power Knob                            |
| 7 | Battery Access Caps                   |
| 8 | SFL Conductive Attachment Output Jack |

**OUTPUT CLAMP JACK**

Insert the MetroClamp phone plug into this jack only.

**CONDUCTOR ARROW**

Align this arrow with your targeted conductor when you are locating in the Inductive mode.

**CHARGE JACK (Optional Feature)**

If you have purchased a 9800 XT with the Rechargeable NiCd Battery feature, your Transmitter will have a jack for connecting the Wall Mount Charger or the Vehicle Mount Charger. The Jack is located on the right inside wall of the Transmitter

**FREQUENCY (Hz) KNOB**

Model 9860XT offers dual frequency output. Model 9890XT can transmit up to three active frequencies.

**Frequencies on 9860XT and 9890XT Transmitter:**

**“AUTO”** - Automatic frequency select

**982Hz - Low audio (9890XT only)**

**9.8kHz** - Audio frequency

**82kHz** - Radio frequency

**“ALL”** - All frequencies are transmitted onto

**BAT CHG (Optional)**

Only on rechargeable units. Battery Charger jack for connecting optional battery charger to Transmitter. Complete recharging is 10-14 hours. Recharge or replace the Transmitter batteries when the battery charge indicator gets below 5 bars.

**FAULT TEST**

The ohm meter indicates the battery charge level and total fault resistance measured on the conductor. The meter continuously displays this value during operation.

**POWER KNOB**

Turn the Power Knob to the “SFL” position to activate fault locating. An audible pulsing tone indicates Transmitter output is active. Turn the Power Knob “OFF” to deactivate Transmitter. The Transmitter will automatically shut off when the battery charge is too low.

**BATTERY ACCESS CAPS**

Remove end caps to gain access to the batteries. Note battery polarity, which is indicated on the bottom of the Transmitter and batteries.

**SFL CONDUCTIVE ATTACHMENT OUTPUT JACK**

Jacks for connecting red and black lead cables to the Transmitter. Maintain the convention of connecting the black cable to the grounding spike and the black lead to the black input. Connect the red cable to the sheath under test, and the red lead to the red input. Failure to do so will cause the A-frame to point toward the ground spike and away from the fault.

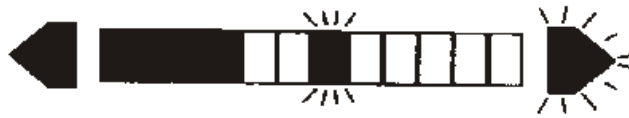
#### 4.5 Transmitter: Features

**LCD BARGRAPH DISPLAY** - The bar graph indicates four types of information:

**BATTERY STATUS** - First 3 seconds the amount of Transmitter battery charge is indicated by the number of bars illuminated.



**CIRCUIT RESISTANCE** - The blinking bar indicates, in ohms, the amount of signal resistance on your conductor and your faulted cable.



**OUTPUT LEVEL** - The solid bars indicate the amount of signal strength (current output) on your conductor.



**POOR CONDUCTOR AND IMPROPER SELECTION** - Entire display blinks and Transmitter beeps very fast or emits a constant beeping tone.



**SPEAKER** (not shown) - Transmitter audio tone changes according to operating function:

| <u>Speaker Tone</u> | <u>Description</u>                           |
|---------------------|--|
| Every 5 seconds     | Good transmitter connection                  |
| Very fast           | Low battery warning and poor conductor alert |
| Constant            | Improper selection alert                     |

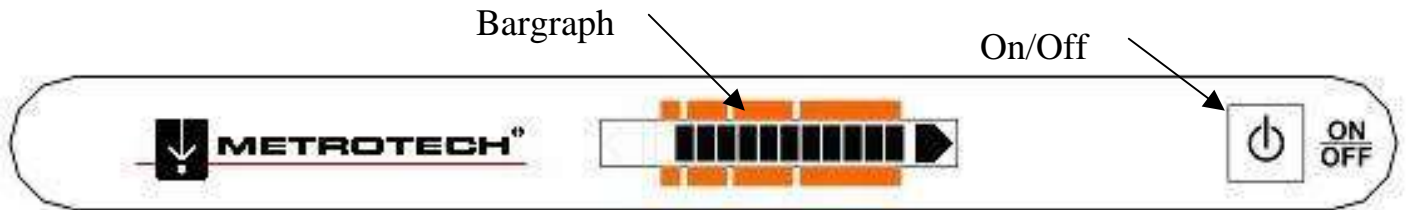
**POWER KNOB** - The amount of transmitter signal output for each power setting changes according to which frequency you are using:

| <b>Power Setting</b>   | <b>Frequency</b> |           |            |
|------------------------|------------------|-----------|------------|
|                        | 982Hz            | 9.82kHz   | 82kHz      |
| L-Low                  | 0.3 watts        | 0.3 watts | 0.15 watts |
| M-Medium               | 1 watt           | 1 watt    | 0.25 watts |
| H-High                 | 3 watts          | 3 watts   | 3 watts    |
| Sheath Fault Locating* |                  | 0.5 watts | 0.35 watts |

\*Sheath Fault Locating - Set at this option for simultaneous sheath fault locating capability. The SFL-2 A-Frame will receive the 4.8Hz sheath fault locating frequency; the 9800XT Receiver will receive the selected active frequency.

#### 4.6 A-Frame Receiver Controls and Indicators

See **Figure 4-3** for location of Receiver controls described below:



**Figure 4-3: A-Frame Controls and Indicators**

**On/Off Button** Push and release to turn “ON”. Push and release to turn “OFF”.

**LCD Bargraph Display:** The bargraph indicates three types of Information:

- **Battery Status** – The solid bars indicate the battery level. If only one bar appears, replace the battery (1 each, 9 volt). The battery status is “ON” for 3 seconds at turn on.



- **Direction of Fault** - The flashing arrows will display the direction to the fault



or



- **Magnitude of Fault** - The number of bars displayed reflect the magnitude of the fault.





## **4.7 Additional A-Frame Receiver Features**

### **4.7.1 Battery Access Plate**

Located on the underside of Receiver control panel. Remove the two thumbscrews to release the plate. See **Figure 9-1** on page 37.

### **4.7.2 Conductive Pads**

The A-Frame Receiver is shipped with two protective foam pads with large washers attached to the Receiver probes. These pads are used for tracing on dry, hard surfaces. Protect and save these conductive pads and washers.

## 5 PRINCIPLES OF OPERATION

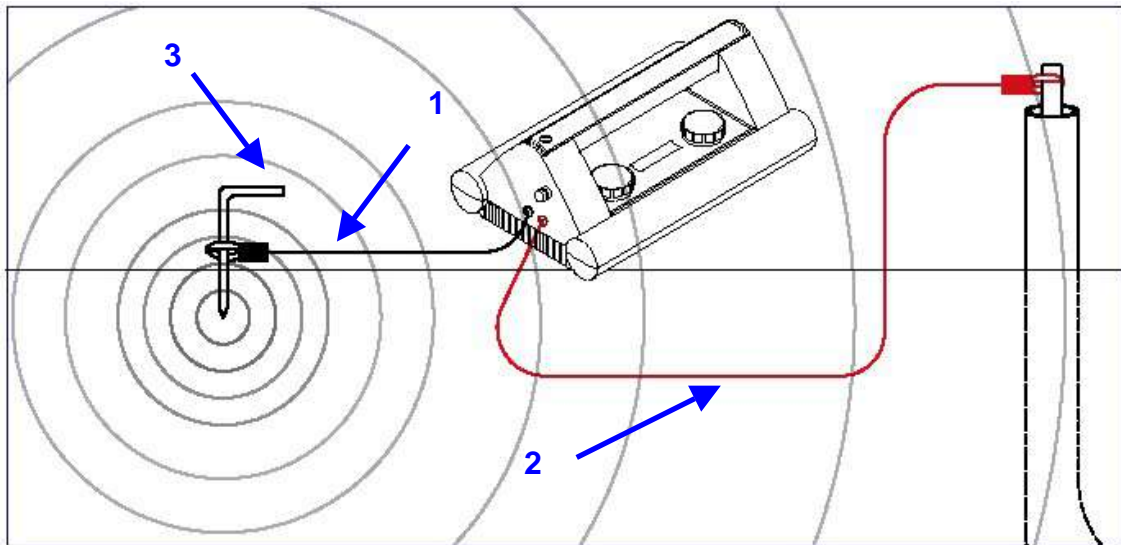
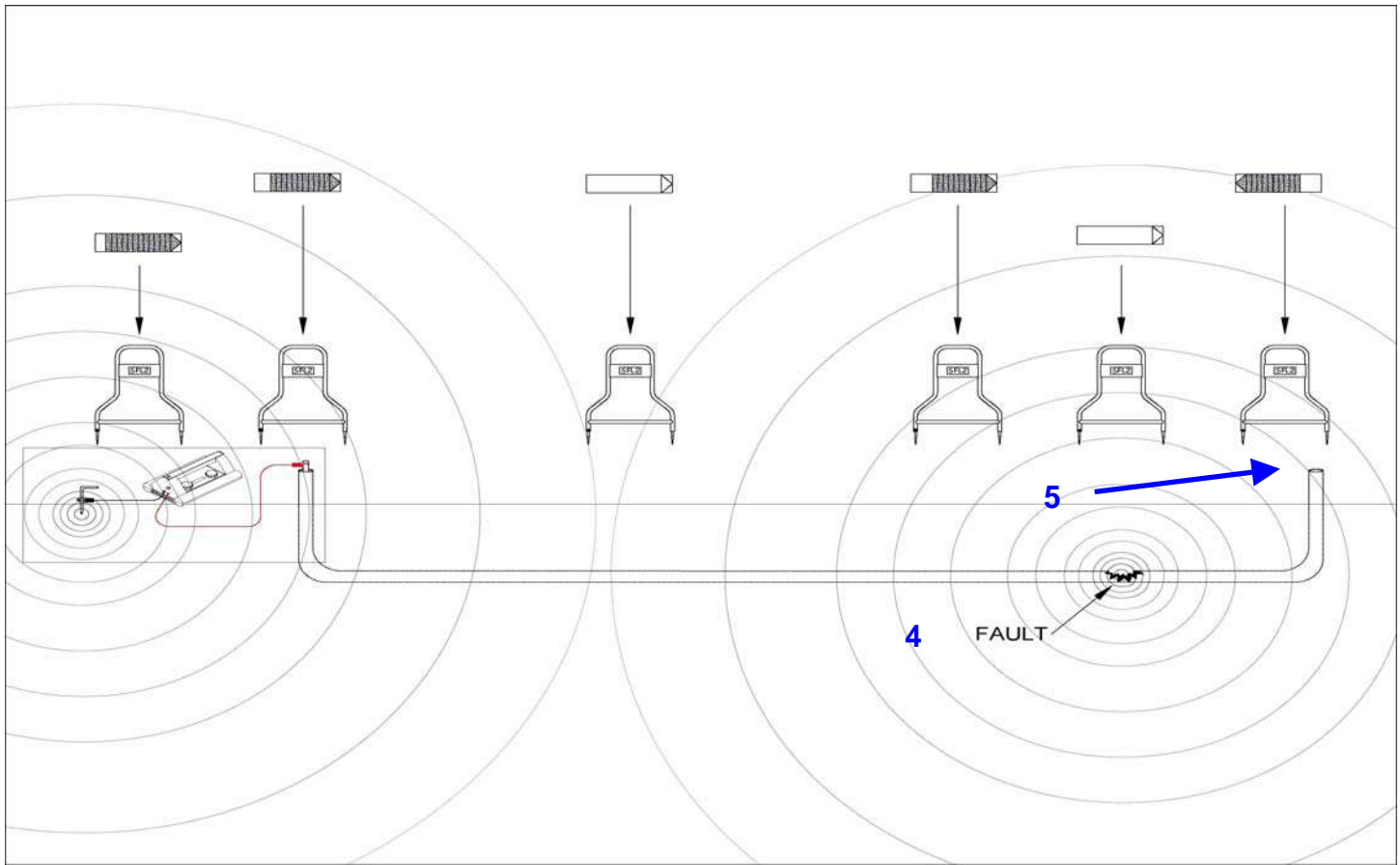
### 5.1 Functional Theory

Even an experienced user needs to review the basics of sheath fault locating before proceeding. This will improve the chances of finding the fault and save valuable time. Comparing electrical current to water flowing through a pipe applies extremely well to fault locating. Trying to find a leak in a water pipe, you might seal off one end, pump water into the other, and look for water to appear near the leak. The principles of sheath fault locating are identical. The cable equivalent of sealing off the pipe is to lift all connections at both ends of the cable, creating a high resistance open condition. The “water” in this case is the current flowing through the cable towards the fault. We look for the current “leak” with an A-Frame”

Both ends of the cable must be disconnected from ground.

The SFL Transmitter applies a low frequency signal (4.8 Hz) between an isolated conductor with an earth fault and another ground point. This induces a signal into the ground from the fault location. This signal pattern is detected by the A-Frame Receiver contact probes.

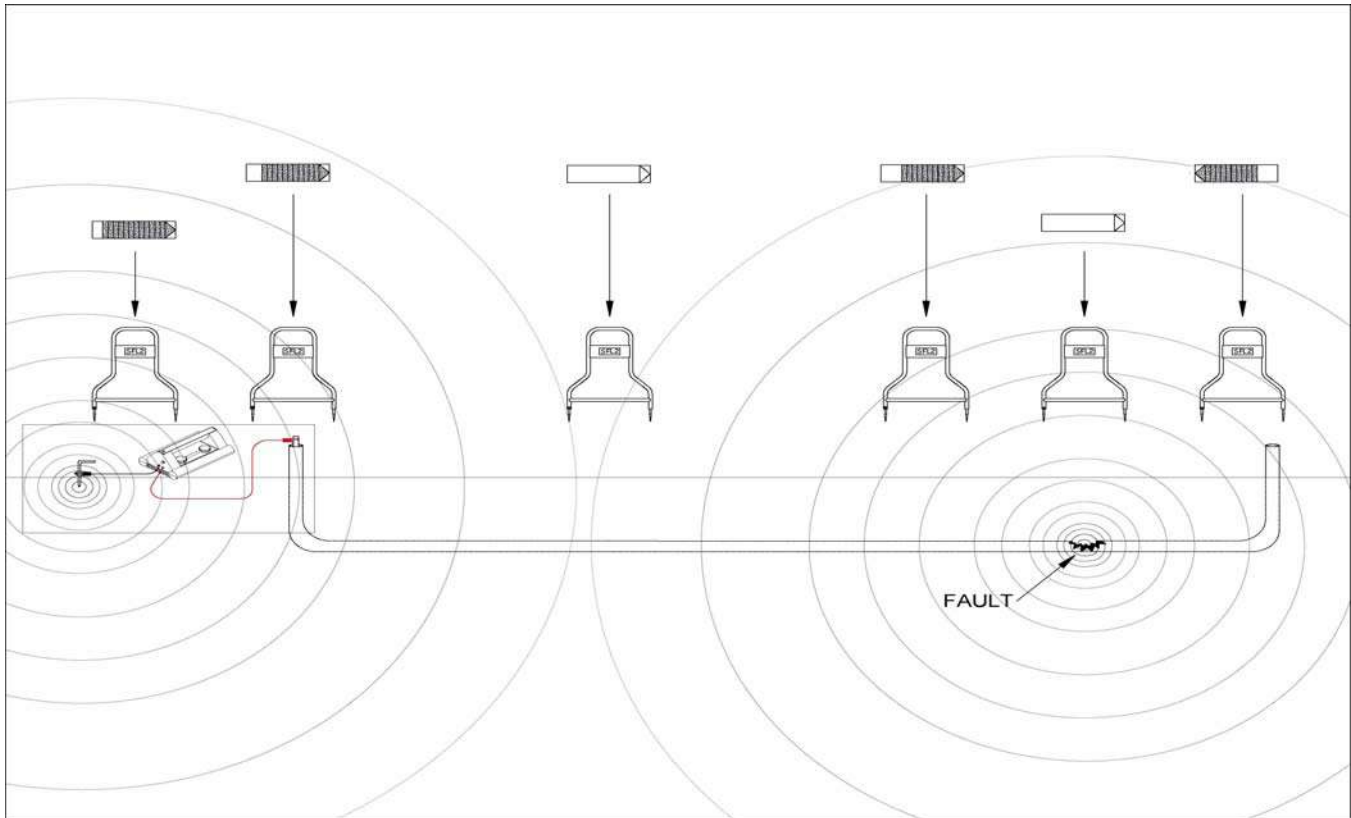
A typical hookup for locating a sheath fault, also called a shield-to-earth fault, is illustrated in **Figure 5-1**.



**Figure 5-1: Typical SFL-2 Transmitter Connection**

- 1 Black Lead
- 2 Red Lead
- 3 Ground Rod
- 4 Fault
- 5 Faulty conductor open on both ends

As current flows from the Transmitter and through the fault, an earth voltage gradient field is created. It is centered at the fault. This gradient field has a pattern such as that depicted in **Figure 5-2**. (Looks like the ripples in a pond when you throw a rock in, or the rings of the stump of a tree.)



**Figure 5-2: Signal Pattern Around Fault and Ground Point.**

The Receiver compares the readings taken by the two probes and determines the direction and size of the fault. Directional blinking arrows guide the operator to the exact source of the fault. The A-Frame's bar graph and numerical active LCD display indicates the relative distance to the fault and its size.

#### **5.1.1. Earth Voltage Gradient**

Note in **Figure 5-2** that the gradient pattern appears to be concentric circles near the fault. Properly interpreting this pattern is the key to successful operation of the 9800SFL unit.

#### **5.1.2. Equipotentials**

The circles shown in **Figure 5-2** represent lines of equal voltage. The boxes show what the bar graph will display with the A-Frame in different positions. Thus, if the A-Frame were inserted so that both of the ground spikes were on the same circle, there would be no difference in voltage between them. The bar graph will show zero, the arrows will become erratic and the numerical active display will show a zero. One of these positions occurs when the fault is directly between the spikes.

This result can also occur midway between the ground spike and a fault and when the A-frame is exactly perpendicular to the fault. There is a return field around the Transmitter ground spike. As you move toward the fault, the bars and the active numerical number will decrease until you reach the midpoint between the fault and ground spikes. At the half waypoint between the fault and ground spike, the signal strength is at its absolute lowest. At this point the bar graph and active display will show zero and the arrows become erratic.

To determine if you are midway between faults or directly over a fault, move the A-Frame further from the Transmitter and measure again. If the arrows tell you to continue in this direction, the zero point was a midpoint. If the arrows tell you to return toward the Transmitter, the zero point was a fault. As you continue, they will increase until you reach the fault.

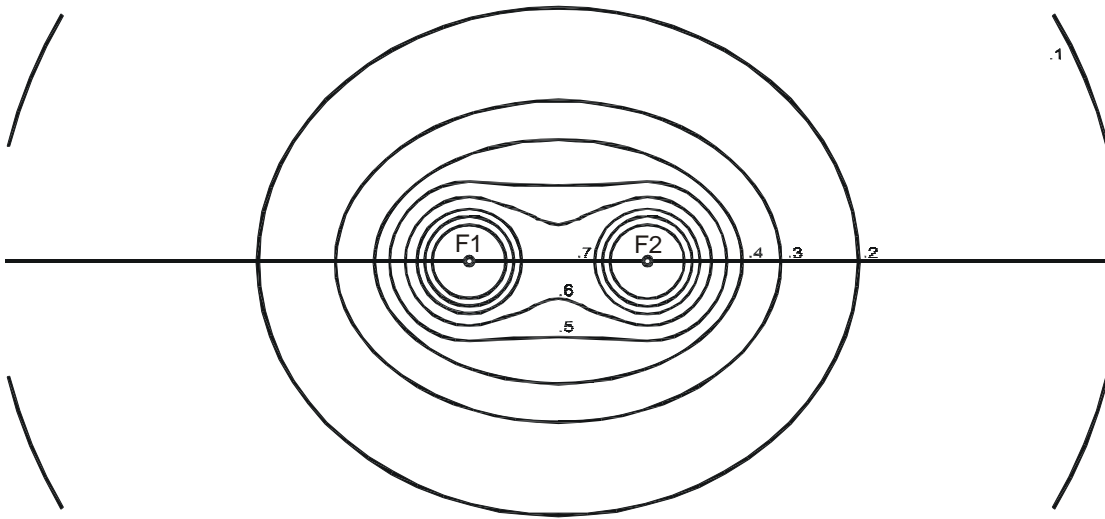
Nearly 70% of the signal exists within the last 1/3 of the distance between the ground spike and the fault. The amount of signal measured and displayed by the A-Frame is proportional to the number of field lines in **Figure 5-2** between the A-Frame spikes. Thus, the maximum signal point occurs when one A-Frame spike is directly above the fault.

One can learn what to expect the A-Frame response at the fault will be by probing around the ground point. As shown in **Figure 5-2**, the signal pattern around the fault and ground point is identical (if there are no nearby conductors). This means that the A-Frame will react the same way around the fault as at the ground point.

As you move toward the fault, the bars and the active numerical display will decrease until you reach the midpoint between the fault and ground spike. As you continue, they will increase until you reach the fault.

### 5.1.3 Multiple Fault Patterns

The signal pattern created by two faults in a line is depicted in **Figure 5-3**. The two faults are shown without the ground point. Notice that from a distance the two faults will have the appearance of a single fault due to the equipotential circle around them both. As you get closer, the individual faults become apparent. There is an area between two faults where the A-Frame may give a false indication of another fault. This is caused by the two faults canceling each other. Errors can be avoided in this situation by following the procedure described in Section 7.7. We recommend that multiple faults be attacked one at a time, i.e., whenever a fault is positively located, it should be repaired before looking for the other faults.



**Figure 5-3: Multiple Fault Signal Patterns**

### 5.1.4 Distortion Due to Adjacent Conductors

Whenever an un-insulated adjacent conductor lies between a fault and the ground return point; the return current tends to concentrate on the conductor instead of flowing through the earth. This can cause shrinkage of the signal pattern near the fault, which would tend to reduce the detectable signal away from the fault. By tracing the faulty conductor first and looking for adjacent conductors before locating the fault, possible problems such as this can be avoided.

## 6 Check Out Procedure

Perform this instrument checkout procedure on a lawn prior to field site use. If grass or dirt is not available, indoor carpeting may be used.

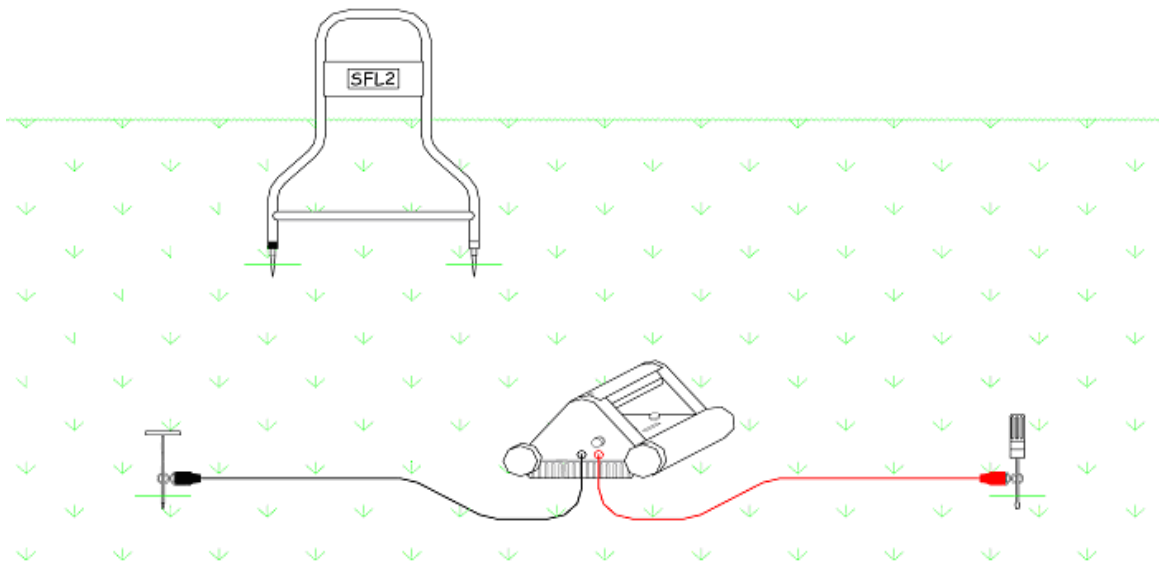
### 1 Check the Batteries.

Turn the Transmitter "ON". The transmitter LCD will display the battery charge status. (If the indicator does not show at least 5 bars replace or recharge the batteries.) Turn the Transmitter "OFF".

Turn the A-Frame Receiver "ON". The solid bars indicate the battery level. If only one bar appears, replace the battery (1 each, 9 volt). The battery status is "ON" for 3 seconds at turn on.

### 2 Connect the Test Cables.

Connect the test cables to the external OUTPUT JACKS. Red cable to red jack, and black cable to black jack. See **Figure 6-1**.



**Figure 6-1: Checkout Test Set-Up**

- 3 Spread the Test Cables as Far Apart as Possible.**  
Insert the ground spike and attach the black cable. Insert a screwdriver into the ground and connect the red cable to it. This will create a simulated fault.  
This test can also be done by pushing the metal end of the clamps directly into the ground so that they make electrical contact.  
When using a carpet in this checkout procedure connect test cable clamps directly to the carpet.
- 4 Turn the Transmitter POWER Knob “ON”**  
Listen for a tone burst and note the indicator for battery condition.
- 5 Synchronize the Receiver.**  
Hold the A-Frame so the black spike is closest to the ground connection. Push the A-Frame into the ground.
- 6 Push the Receiver On/Off Switch to “ON”.**  
The A-Frame Receiver will repeat its battery test. After the battery test, the arrow facing the simulated fault (red test clamp) flashes and a potential gradient number is displayed on the Active and Reference LCD display
- 7 Rotate the A-frame 180 Degrees.**  
Note that the arrow now facing the red test clamp flashes. As the A-Frame is moved around the fault the arrow closest to the simulated fault should flash.



## 7 OPERATION

### 7.1 Check the batteries prior to going into the field.

Follow the Transmitter battery check procedures as given on page 4.

Turn the A-Frame Receiver “ON”. The solid bars indicate the battery level. If only one bar appears, replace the battery (1 each, 9 volt). The battery status is “ON” for 3 seconds at turn on.

### 7.2 Ensure all conductors are de-energized.

### 7.3 Lift the grounds.

Lift the grounds (of all conductors in the circuit) at both ends of the faulted cable section. Occasionally, the very experienced fault locators see evidence (i.e. tripped circuit breakers at transformer) that the fault is so severe that no signal will travel beyond the fault. In these cases, it is not necessary to lift the distant ground.

#### **WARNING!**

**When the Transmitter is set to “SFL” the external OUTPUT JACK produce up to 1200 volts. Do not touch these jacks, electrical shock will result!**

#### **CAUTION!**

**Do not place a shorting bar across external Output Jacks, or connect the two leads together. Damage to the Transmitter may result.**

### 7.4 Attach the Transmitter to the conductor and check the fault resistance.

- 1 Turn the Transmitter “OFF”
- 2 Plug the Black and Red leads into the Transmitter.
- 3 Clamp Red lead to target conductor sheath. Make sure the red clamp does not make contact with any leaves, grass, or dirt. This could create false reading.
- 4 Stretch black lead 180 degrees away from the Conductor.
- 5 Push grounding rod into the earth and clamp the Black lead to the grounding rod. Establish the best ground possible.
- 6 Turn Transmitter Power knob to “SFL” position. Transmitter will repeat battery test.
- 7 Check fault resistance. Severe faults read in the 0-100K ohms, medium faults will read in the 100K – 500K ohms, and light faults will read 1 Megohm and up. Turn the frequency knob on the Transmitter to select a tracing frequency. In SFL mode, the Transmitter will simultaneously send 4.8 Hz fault locating frequency and 9.8 Hz or 82kHz cable tracing frequency.

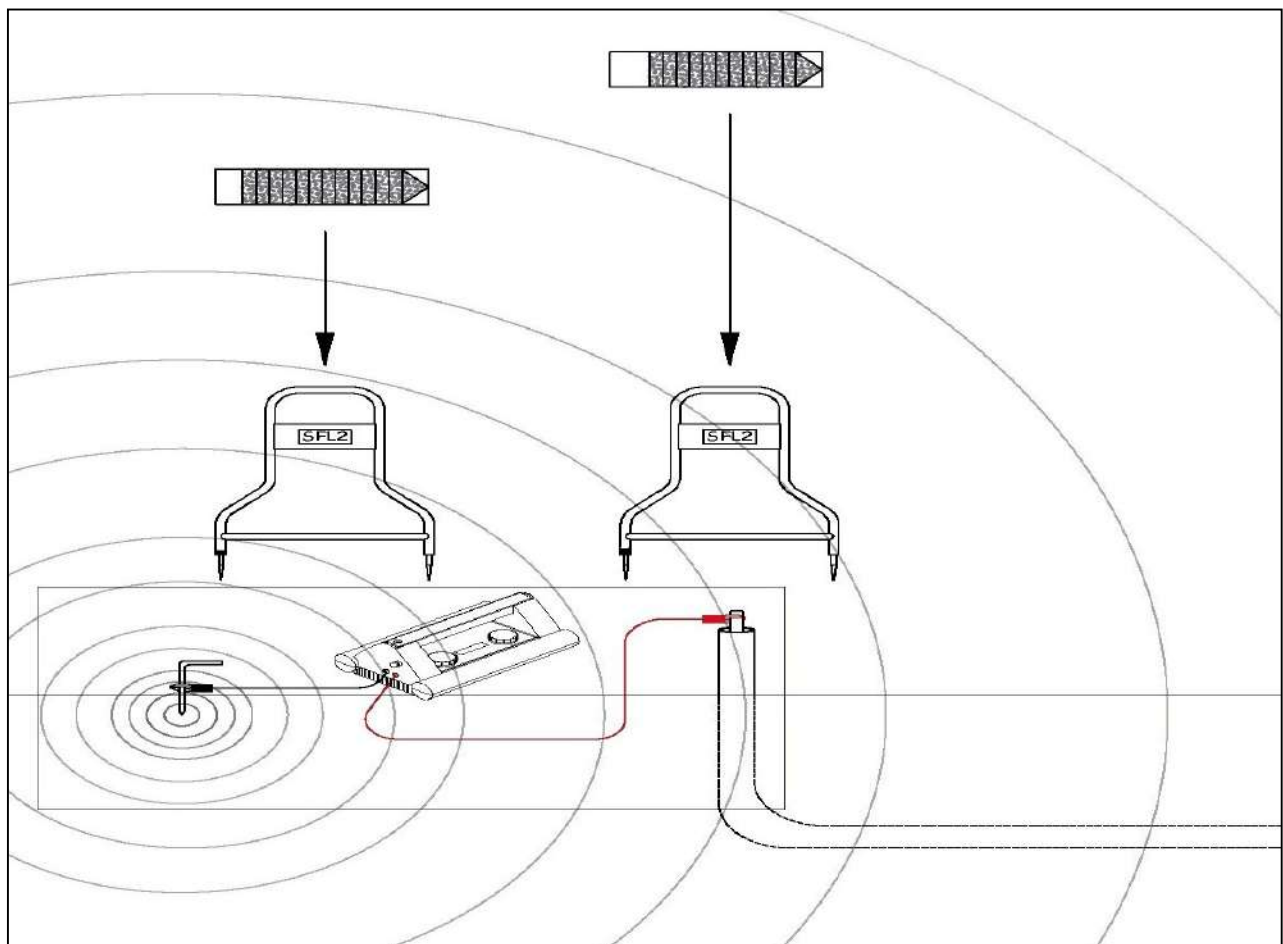
### 7.5 Synchronize the A-Frame Receiver

By synchronizing, the A-Frame memorizes the phase of the Transmitter signal. This allows it to recognize the reverse phase signal coming from the fault and direct you to it.

**Note:**

Resynchronize the Receiver every 45 minutes to maintain calibration. You may do this near the ground rod or near a fault. At the ground rod, the black A-Frame spike must be nearest the ground rod. At a fault, the white A-Frame spike must be nearest the fault.

- 1 Hold the A-Frame so the black spike is closest to the ground rod.
- 2 Push the A-Frame spikes into the ground.
- 3 Switch the Receiver "ON". Wait until the arrow flashes.
- 4 If the arrow points away from the ground spike, there is a fault.
- 5 If the arrow points towards the ground spike, there is not fault, or grounds and connections need to be rechecked. See **Figure 7-1**.



**Figure 7-1: Synchronizing The A-frame**

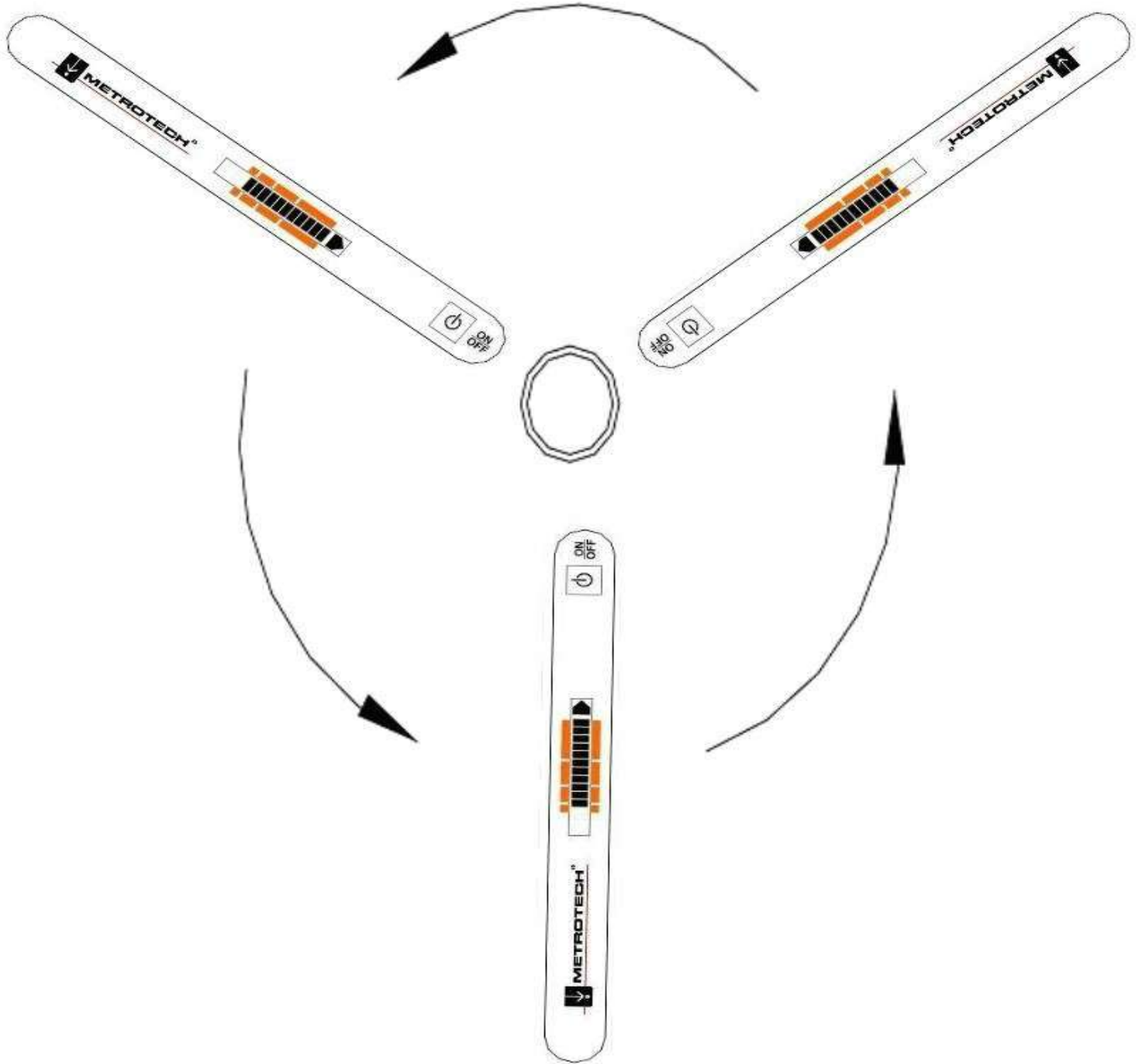


Figure 7-2: Fault Confirmation

**7.5 Confirm that a fault exists.**

- 1 Remove the A-Frame from the ground.
- 2 Rotate it 180 degrees and re-insert it into the ground. The arrows should reverse directions and point away from the ground spike.

**7.6 Trace the cable with the 9800 Receiver.**

The 9800 Line Locators allows you to trace the line and search for the fault at the same time.

- 1 Check the 9800 Receiver for cable tracing frequency. Aim the Receiver at the Red lead and cycle through the Receiver frequencies to confirm that the selected tracing frequency is being received.
- 2 Trace and mark the cable as you proceed towards the fault.

**7.7 Pinpoint the fault.**

- 1 Keep the A-Frame parallel to the target cable
- 2 Insert the A-Frame every 10-20 feet. Follow the arrow and monitor the active number.
- 3 When locating with the A-Frame, make sure that the probes are inserted well into the ground. A good physical ground connection is needed to receive strong signal.
- 4 When the arrow changes direction, back track. Check the active number and compare it to the reference number. If both active and reference numbers have the same or similar value, you have found the major fault.
- 5 Insert the A-Frame every two feet until the arrow changes direction again, then turn it 90 degrees. Check for obvious causes where a fault is suspected, such as recent excavation.
- 6 Continue to move the A-Frame across the cable until a slight movement causes the arrow to change directions. When this happens, the fault is located at the center of the A-Frame.

**7.8 Verify the fault.**

- 1 Move slightly off to one side of the cable.
- 2 Insert the A-Frame into the ground at various positions around the suspected fault site (like the hands of a clock).
- 3 The arrow should always point toward the fault.
- 4 Place the other spike in the ground at the fault site and repeat the process. The arrow should always point inward, toward the fault

Place the other spike in the ground at the fault site and repeat the process. The arrow should always point inward, toward the fault.

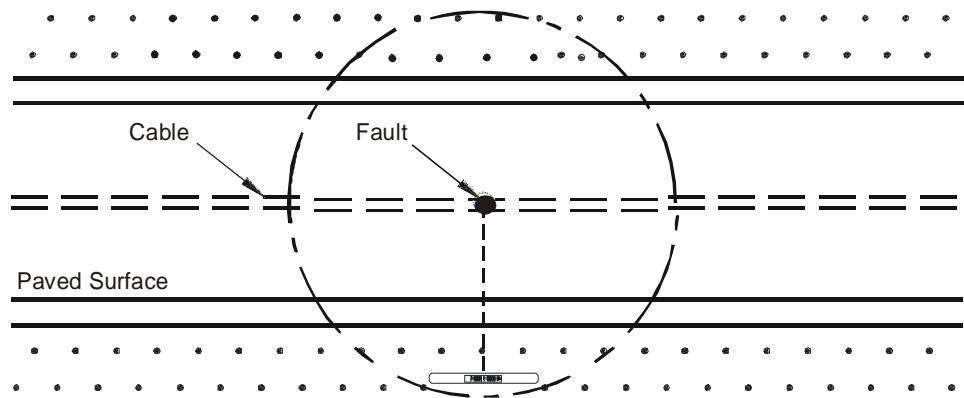
## 8 Advanced Techniques

### 8.1 Faults Under Inaccessible Surfaces.

When the faults exist beneath a paved or other inaccessible area, the fault may be located using one of the following methods.

#### 8.1.1. Perpendicular Method.

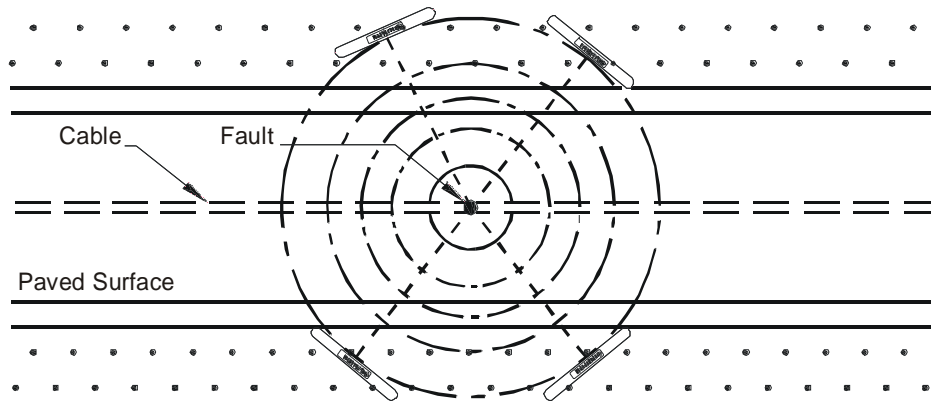
Carefully trace the location of the faulty conductor. Hold the A-Frame parallel to the cable path. As you move away from the ground rod the bar graph and the active number will gradually decrease until reaching the midpoint. It will then increase until reaching the fault. When the A-Frame center passes a line perpendicular to the sheath fault, the directional arrow indicators will rapidly change positions and the bar graph and active number will drop to zero. See **Figure 8-1**.



**Figure 8-1: Perpendicular Method**

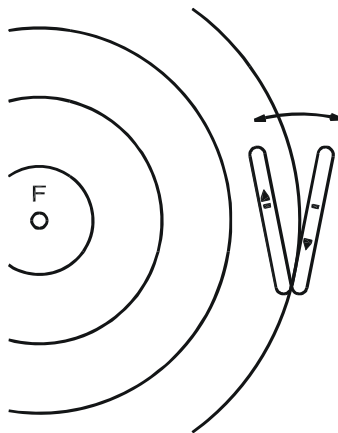
### Triangulation Method.

As shown in **Figure 8-2**, (the point where the signal strength is a minimum) if the A-Frame is positioned exactly on an equipotential circle, a perpendicular line from the center of the A-Frame will pass through the fault. The intersection of any two such perpendicular lines defines the fault location.



**Figure 8-2: Triangulation Method**

To find an equipotential circle (see **Figure 8-3**) insert the A-Frame into the ground and pivot around one spike. Rotate the A-Frame back and forth until the exact point is found where the flashing arrows change direction. The A-Frame is now on an equipotential circle and is perpendicular to the fault. By marking this line and repeating the process with the A-Frame at another nearby location, the two lines will intersect or cross at the fault.



**Figure 8-3: Locating an Equipotential Circle**

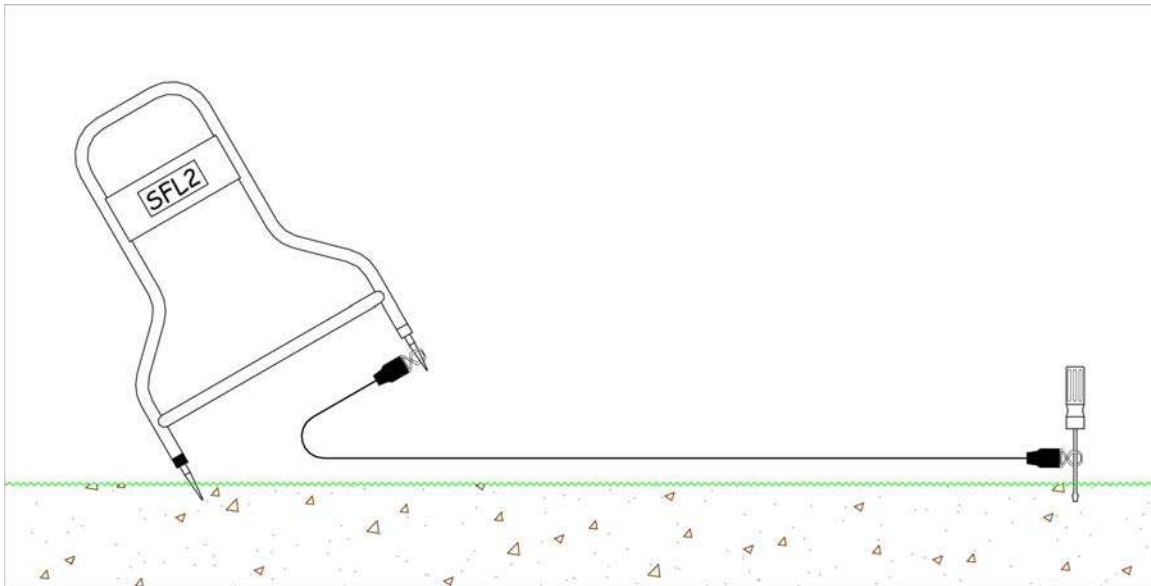
## 8.2 Faults Under Pavement

Faults under pavement or other slightly conductive surfaces can be found using the foam pads supplied with the unit. Saturate the pads with water and insert the A-Frame spikes into the pads. Locate the fault as you normally would. Be sure to keep the pads as moist as possible, but do not let the water form a continuous puddle between the pads as this will short out the signal.

## 8.3 Long Distance Tracing.

As the distance to the fault increases, the signal picked up by the A-Frame is proportionally reduced. This condition can lead to problems if the signal levels are reduced to the point that they can no longer be detected by the A-Frame.

Whenever working with weak signals due to long distance faults (or other reasons), increased sensitivity can be obtained by extending the distance between the A-Frame spikes using the extension cable. This extension method can be applied to any of the previously discussed methods including the conductive foam pads. When working with very long distances, as in fiber optic runs, the sensitivity can be increased even further using a longer insulated wire to extend the A-Frame span. See **Figure 8-4**.



**Figure 8-4: Fault Location Using Extension Cable for Increased Sensitivity**

#### **8.4 High and Low Impedance Faults.**

Before beginning a fault search it is a good idea to know the severity of the fault. This is measured in terms of it is resistance or impedance to ground. Faults where the ground is wet and/or a very large piece of the insulation is missing are found at the low end of the range (<500 ohms). Conditions where the ground is very dry and/or the actual fault is a small pinhole where the conductor has a very small ground contact area are found at the high end of the fault range (>1-3 megohms).

A low impedance fault is the easiest to find since there is more signal to detect. Generally, the more bars and a higher number displayed at synchronization, the larger the fault.

A high impedance fault is more difficult to locate. Characteristically, the Receiver may not detect the signal after moving a short distance away from the ground point. The higher the impedance of the fault, the closer you must be to detect it.

For Example.

If the A-Frame only reliably points away from the ground connection within 10 feet, then the A-frame will only detect the fault within about 10 feet. Outside this distance the signal is too weak to reliably detect.

For this reason we highly recommend tracing and marking the line before searching out high impedance faults.

#### **8.5 Multiple Faults**

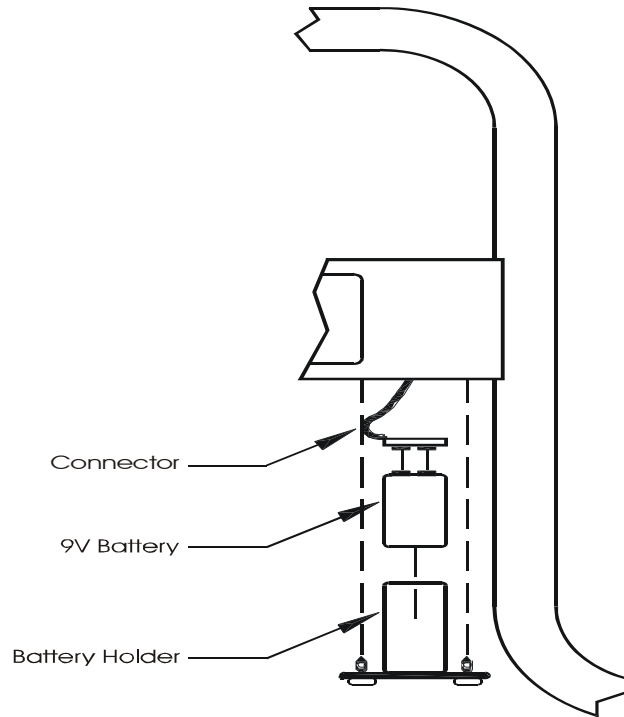
Locating multiple faults is the most difficult and confusing fault situation. It is especially important in this case to accurately trace the faulty conductor before beginning the fault search. Stay exactly above the line if possible and verify each suspected fault by monitoring the active number to see which fault has the higher number. Remember that a very strong or low impedance fault will mask the detection of a weak or high impedance fault. The safest and best way to find multiple faults is to repair, each fault as it is positively identified and then continue the search. See **Figure 5-3**.



## 9 MAINTENANCE

### 9.1 Receiver Battery Replacement.

Loosen the two thumbscrews located on the underside of the Receiver housing. Gently pull out battery door. Be careful not to pull on the battery wires. Remove battery from battery holder and disconnect battery. Reverse procedure for installing new battery.



**Figure 9-1: Receiver Battery Replacement**

## 9.2 Service Centers

If the instrument does not function properly, replace the battery as described above. If the equipment still malfunctions, contact one of our Metrotech Customer Service departments for assistance:

### **Metrotech West Coast Service Center**

3251 Olcott Street  
 Santa Clara, CA 95054  
 Telephone: 408-730-1400  
               800-638-7682  
 Fax: 408-734-1415  
 E-mail: [service@metrotech.com](mailto:service@metrotech.com)  
 Internet: [www.metrotech.com](http://www.metrotech.com)

### **Metrotech East Coast Service Center**

1824 Murfreesboro Road Suite 104  
 Nashville, TN 37217  
 Telephone: 800-624-6210  
               615-366-7323  
 Fax: 615-360-9855  
 E-mail: [Nashville@metrotech.com](mailto:Nashville@metrotech.com)

### **Metrotech Northeast Sales/Service Center**

89 South Commerce Way  
 Suite 940  
 Bethlehem, PA 18017  
 Telephone: 866-644-8537  
               610-861-1996  
 Fax: 610-861-1935  
 E-mail: [ecoast.service@metrotech.com](mailto:ecoast.service@metrotech.com)  
 Internet: [www.metrotech.com](http://www.metrotech.com)

### **European Service Center Seba Dynatronic**

Mess-Und Ortungs-technik GmbH  
 Dr. Herbert Iann Str. 6  
 D- 96148 Baunach Germany  
 Telephone: + 49-9544-680  
 Fax: + 49-9544-2273  
 E-mail: [service@sebakmt.com](mailto:service@sebakmt.com)  
 Internet: [www.sebakmt.com](http://www.sebakmt.com)

Or call the factory for the nearest authorized Metrotech repair station.

Additional Metrotech Instruments: Pipe and Cable Locators, Dual Frequency Locators, Magnetic Locators, Fiber Optic Cable Locating System, Leak Detectors, Valve Box Locators, and High Power Locators.

## APPENDIX

**A1 APWA Marking Colors** - The following color markings have been established by the American Public Works Association (APWA):

| <b>Conductor</b>                                   | <b>Color</b> |
|--|--------------|
| Electric power lines, cables,<br>or conduits       | Red          |
| Communication lines, cables,<br>conduits, CATV     | Orange       |
| Gas, oil, petroleum, or other<br>gaseous materials | Yellow       |
| Sewers, storm and sanitary,<br>drain lines         | Green        |
| Water, irrigation, or slurry lines                 | Blue         |

**Note:** If you have any questions regarding marking requirements or procedures in the United States, please call you local One Call Center. International customers: please check with your local regulatory authorities or utility companies required color markings may vary between different countries.

## **COPYRIGHT NOTICE**

The information contained in this document is for informational purposes only and is subject to change without notice.

Metrotech Corporation makes no warranty of any kind with regard to the information contained in this manual, including but not limited to the implied warranties of merchantability and fitness for a particular purpose. Metrotech shall not be liable for errors contained herein, nor for incidental or consequential damages from the furnishing of this information.

This manual contains proprietary information that is protected by copyright. All rights are reserved. No part of this manual may be photo-copied, reproduced, magnetically stored, transmitted, or translated into another language without the prior written consent of Metrotech Corporation.

**© Metrotech Corporation 2005**

## **WARRANTY**

THERE ARE NO WARRANTIES, EXPRESSED OR IMPLIED, INCLUDING ANY WARRANTY OF MERCHANTABILITY, BEYOND THOSE STATED HEREIN.

Metrotech warrants it is equipment to be free from defects in workmanship and material under normal and proper use and service for one year from date of purchase by original user. Metrotech assumes no obligation to repair or replace equipment which has been altered or repaired by other than a Metrotech-approved procedure, been subject to misuse, misapplication, improper maintenance, negligence, or accident; has had its serial number or any part hereof altered, defaced or removed; or been used with parts other than those approved by Metrotech. Warranty does not include batteries. Expendable items such as fuses and lamps are excluded.

Any detection product proved defective under this warranty will be repaired or replaced free of charge at the Metrotech Corporation factory or approved Metrotech repair station. The equipment should be returned to our factory by prepaid transportation after requesting and receiving return authorization from our Service Department.

Metrotech's obligations are limited to repair or replacement of broken or defective parts, which have not been abused, misused, altered, or accidentally damaged, or at the option of Metrotech, to refund of the purchase price. Metrotech assumes no liability for removal or installation costs, consequential damages, or contingent expenses of any other nature.

Part #: 600A113  
Price: \$10.00 US